

Quad High Side Micropower MOSFET Driver with Internal Charge Pump

FEATURES

- No External Charge Pump Components
- Fully Enhances N-Channel Power MOSFETs
- 16 Microamps Standby Current
- 95 Microamps ON Current
- Wide Power Supply Range 4.5V to 18V
- Controlled Switching ON and OFF Times
- Replaces P-Channel High Side Switches
- Compatible with Standard Logic Families
- Available in 16-pin SOL Package

APPLICATIONS

- Laptop Computer Power Switching
- SCSI Termination Power Switching
- Cellular Telephone Power Management
- P-Channel Switch Replacement
- Battery Charging and Management
- Low Frequency H-Bridge Driver
- Stepper Motor and DC Motor Control

DESCRIPTION

The LTC1156 quad High side gate driver allows using low cost N-channel FETs for high side switching applications. An internal charge pump boosts the gate drive voltage above the positive rail, fully enhancing an N-channel MOS switch with no external components. Micropower operation, with 16 μ A standby current and 95 μ A operating current, allows use in virtually all systems with maximum efficiency.

Included on chip is independent over-current sensing to provide automatic shutdown in case of short circuits. A time delay can be added to the current sense to prevent false triggering on high in-rush current loads.

The LTC1156 operates off of a 4.5V to 18V supply and is well suited for battery-powered applications, particularly where micropower "sleep" operation is required.

The LTC1156 is available in both 16-pin DIP and 16-pin SOL packages.

TYPICAL APPLICATION

Laptop Computer Power Management

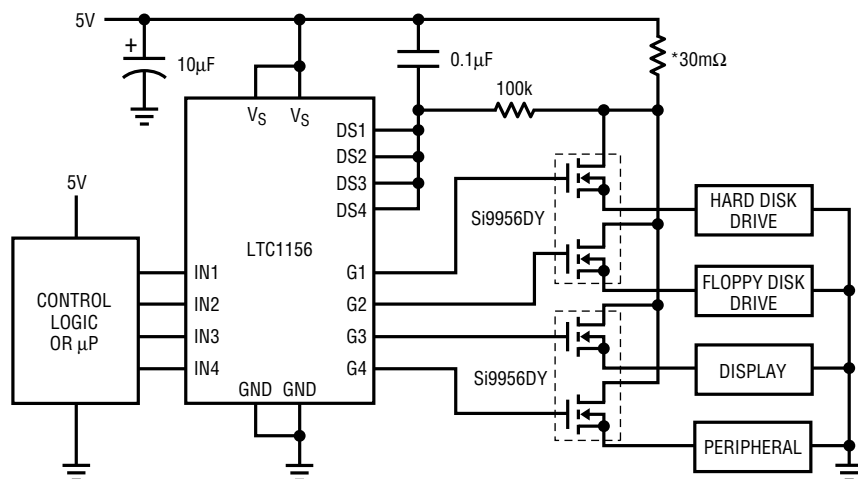

Standby Supply Current

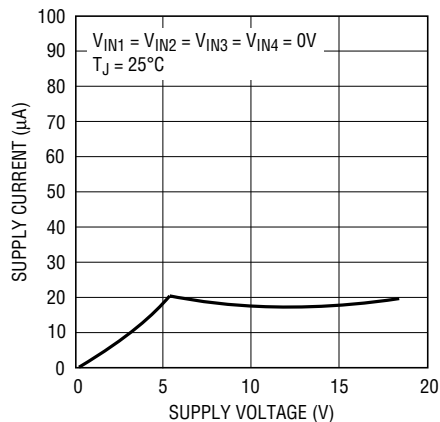

ALL COMPONENTS SHOWN ARE SURFACE MOUNT. MINIMUM PARTS COUNT SHOWN. CURRENT LIMITS CAN BE SET SEPARATELY AND TAILORED TO INDIVIDUAL LOAD CHARACTERISTICS.

* IMS026 INTERNATIONAL MANUFACTURING SERVICES, INC. (401) 683-9700

1156 TA01

ABSOLUTE MAXIMUM RATINGS

Supply Voltage	22V	Operating Temperature Range	
Input Voltage	($V_S + 0.3V$) to ($GND - 0.3V$)	LTC1156C	0°C to 70°C
Gate Voltage	($V_S + 24V$) to ($GND - 0.3V$)	Storage Temperature Range	-65°C to 150°C
Current (Any Pin)	50mA	Lead Temperature (Soldering, 10 sec.)	300°C

PACKAGE/ORDER INFORMATION

<p>N PACKAGE 16-LEAD PLASTIC DIP $T_{JMAX} = 110^{\circ}C, \theta_{JA} = 120^{\circ}C/W$</p>	<p>ORDER PART NUMBER</p> <p>LTC1156CN</p>	<p>S PACKAGE 16-LEAD PLASTIC SOL $T_{JMAX} = 110^{\circ}C, \theta_{JA} = 130^{\circ}C/W$</p>	<p>ORDER PART NUMBER</p> <p>LTC1156CS</p>
---	---	---	---

Consult factory for Industrial and Military grade parts.

ELECTRICAL CHARACTERISTICS $V_S = 4.5V$ to $18V, T_A = 25^{\circ}C$, unless otherwise noted.

SYMBOL	PARAMETER	CONDITIONS	MIN	TYP	MAX	UNITS	
V_S	Supply Voltage	(Note 1)	●	4.5	18	V	
I_Q	Quiescent Current OFF	$V_S = 5V, V_{IN} = 0V$ (Note 2)		16	40	μA	
I_Q	Quiescent Current ON	$V_S = 5V, V_{IN} = 5V$ (Note 3)		95	125	μA	
I_Q	Quiescent Current ON	$V_S = 12V, V_{IN} = 5V$ (Note 3)		180	400	μA	
V_{INH}	Input High Voltage		●	2.0		V	
V_{INL}	Input Low Voltage		●		0.8	V	
I_{IN}	Input Current	$0V < V_{IN} < V_S$	●		± 1.0	μA	
C_{IN}	Input Capacitance			5		pF	
V_{SEN}	Drain Sense Threshold Voltage		●	80 75	100 100	120 125	mV mV
I_{SEN}	Drain Sense Input Current	$0V < V_{SEN} < V_S$	●		± 0.1	μA	
$V_{GATE} - V_S$	Gate Voltage Above Supply	$V_S = 5V$ $V_S = 6V$ $V_S = 12V$	● ● ●	6.0 7.5 15	7.0 8.3 18	9.0 15.0 25	V V V
t_{ON}	Turn-ON Time	$V_S = 5V, C_{GATE} = 1000pF$ Time for $V_{GATE} > V_S + 2V$ Time for $V_{GATE} > V_S + 5V$		50 200	250 1100	750 2000	μs μs
		$V_S = 12V, C_{GATE} = 1000pF$ Time for $V_{GATE} > V_S + 5V$ Time for $V_{GATE} > V_S + 10V$		50 120	180 450	500 1200	μs μs

ELECTRICAL CHARACTERISTICS $V_S = 4.5V$ to $18V$, $T_A = 25^\circ C$, unless otherwise noted.

SYMBOL	PARAMETER	CONDITIONS	MIN	TYP	MAX	UNITS
t_{OFF}	Turn-OFF Time	$V_S = 5V$, $C_{GATE} = 1000pF$ Time for $V_{GATE} < 1V$	10	36	60	μs
		$V_S = 12V$, $C_{GATE} = 1000pF$ Time for $V_{GATE} < 1V$	10	26	60	μs
t_{SC}	Short Circuit Turn-OFF Time	$V_S = 5V$, $C_{GATE} = 1000pF$ Time for $V_{GATE} < 1V$	5	16	30	μs
		$V_S = 12V$, $C_{GATE} = 1000pF$ Time for $V_{GATE} < 1V$	5	16	30	μs

The ● denotes specifications which apply over the full operating temperature range.

Note 1: Both V_S pins (3 and 8) must be connected together, and both ground pins (1 and 6) must be connected together.

Note 2: Quiescent current OFF is for all channels in OFF condition.

Note 3: Quiescent current ON is per driver and is measured independently.

TYPICAL PERFORMANCE CHARACTERISTICS

Standby Supply Current

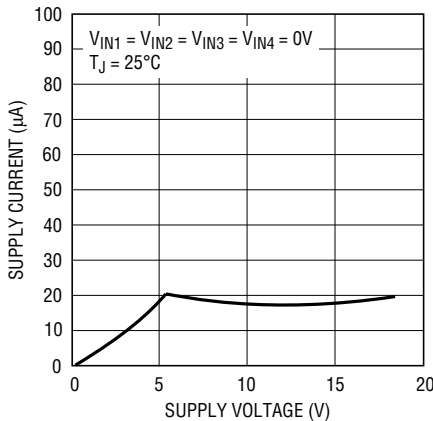

LTC1156 G01

Supply Current per Channel ON

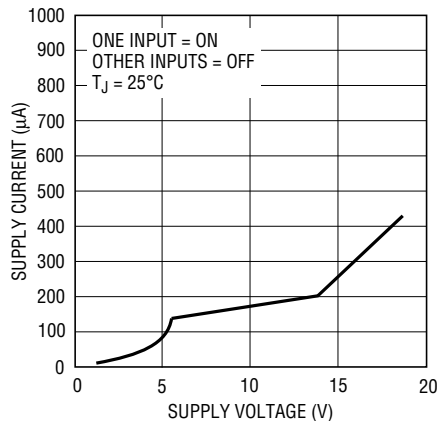

1156 G02

High Side Gate Voltage

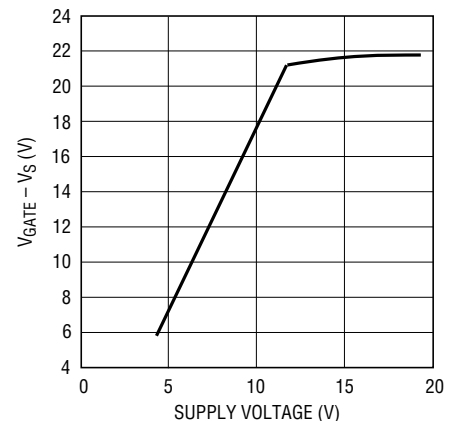

LTC1156 G03

Standby Supply Current

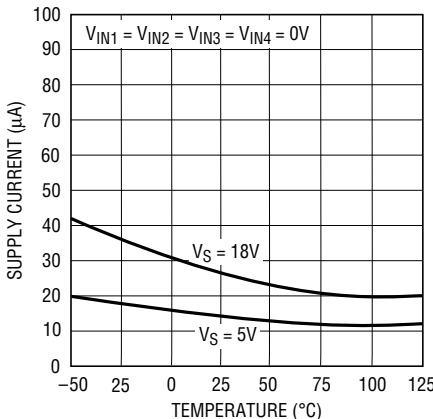

1156 G04

Supply Current per Channel ON

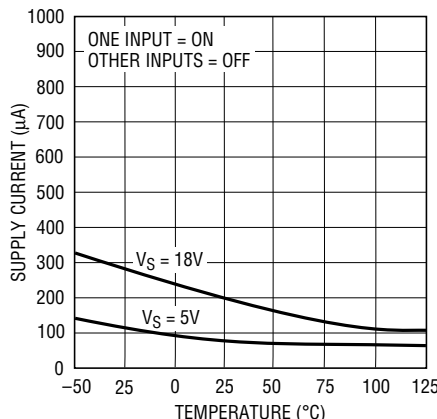

1156 G05

Low Side Gate Voltage

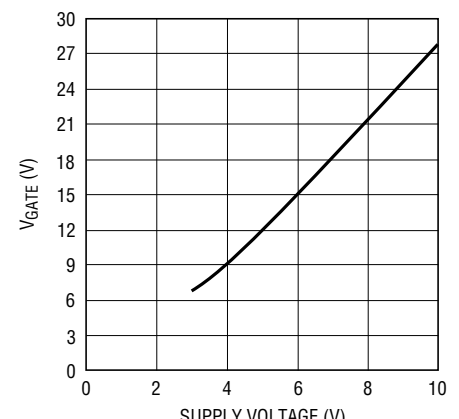

1156 G06

TYPICAL PERFORMANCE CHARACTERISTICS

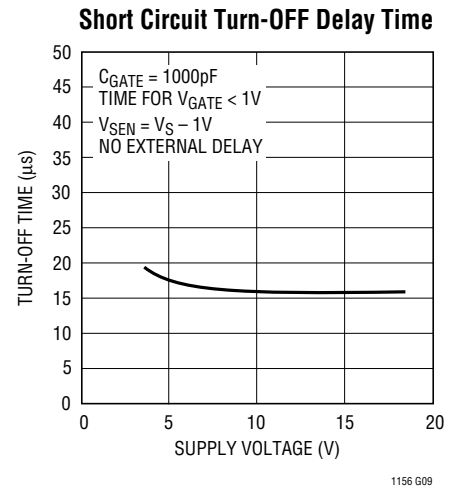
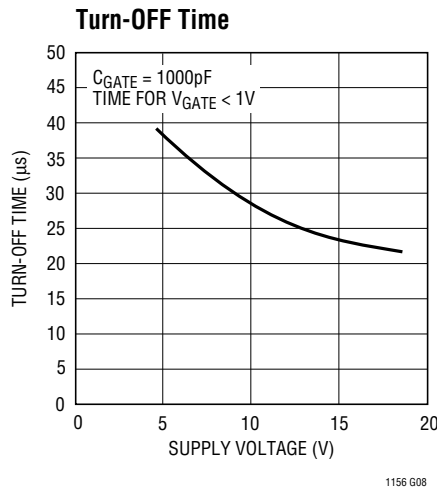
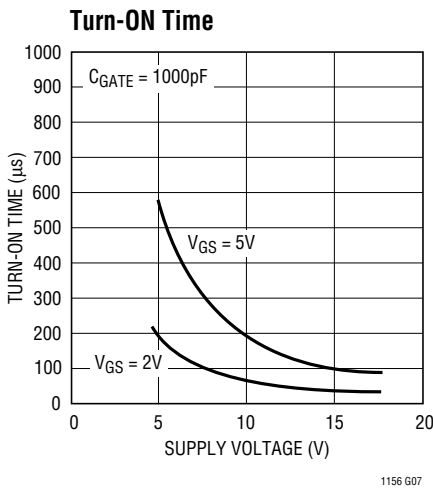

BLOCK DIAGRAM

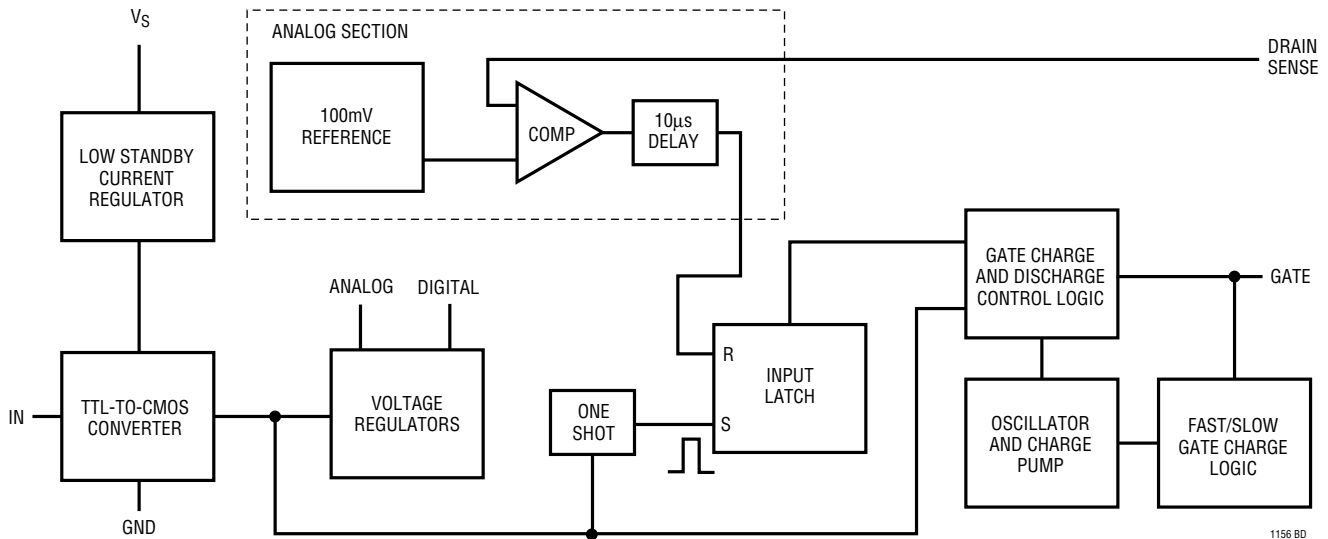

OPERATION

The LTC1156 contains four independent power MOSFET gate drivers and protection circuits (refer to the Block Diagram for detail). Each section of LTC1156 consists of the following functional blocks:

TTL and CMOS Compatible Inputs

Each driver input has been designed to accommodate a wide range of logic families. The input threshold is set at 1.3V with approximately 100mV of hysteresis.

TYPICAL APPLICATIONS

24V to 30V Quad Industrial Switch with Thermal Shutdown

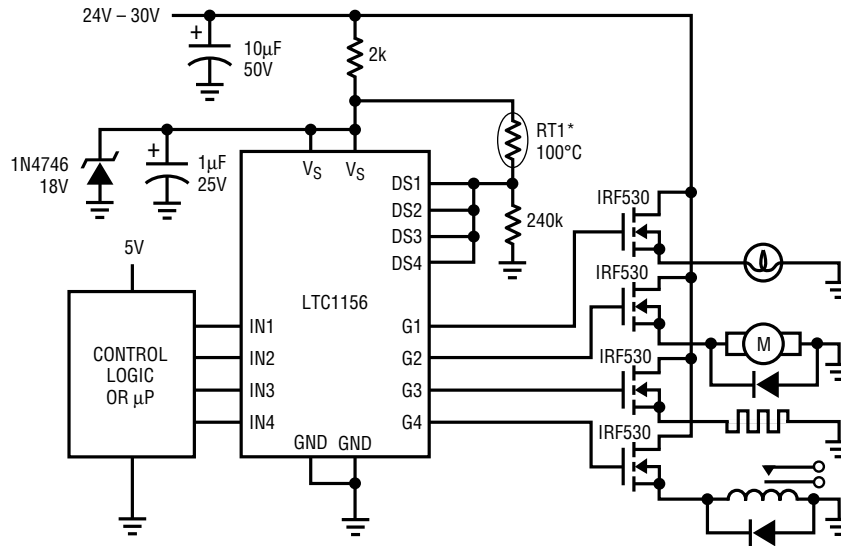

* KEYSTONE RL2006-100-100-30-PT MOUNT ON HEATSINK.

1156 TA03

Automotive Triple High Side Switch with Reverse Battery Interrupt, Short-Circuit and High-Voltage Transient Protection (20µA Standby Current)

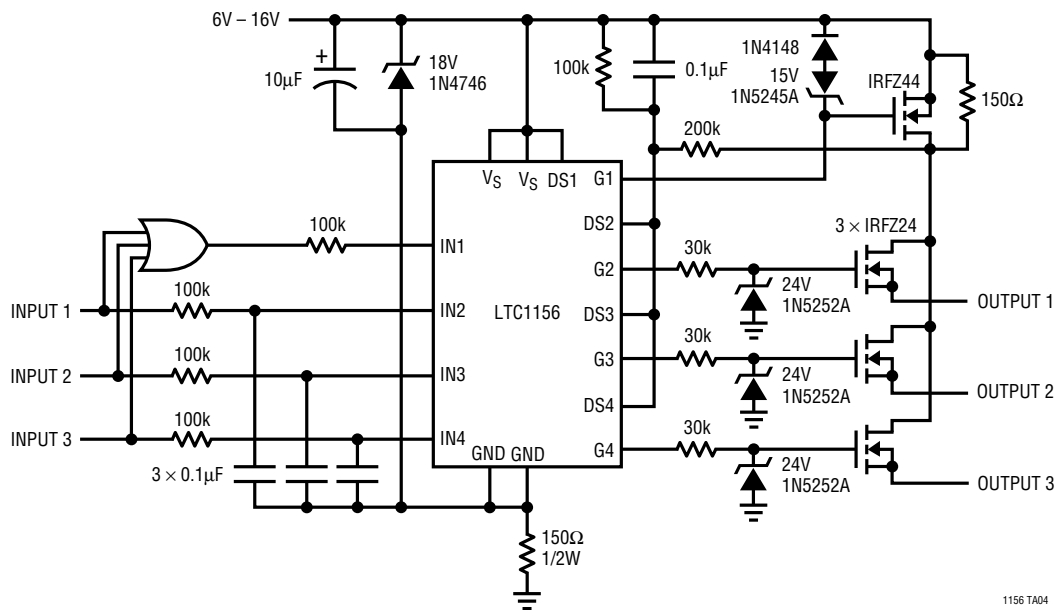

1156 TA04

TYPICAL APPLICATIONS

4-Phase Stepper Motor Driver with Short-Circuit Protection

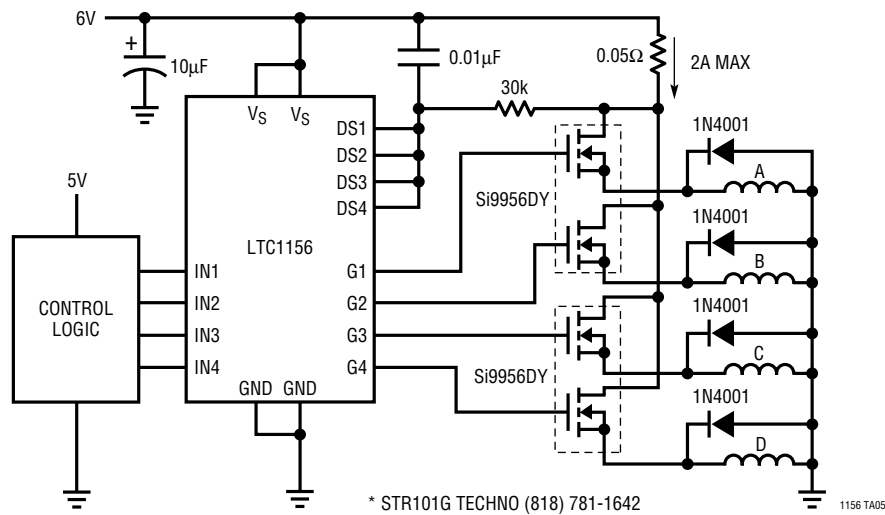

Full H-Bridge Driver with Short-Circuit Protection and 16µA Standby Current Low Frequency Operation (<100Hz)

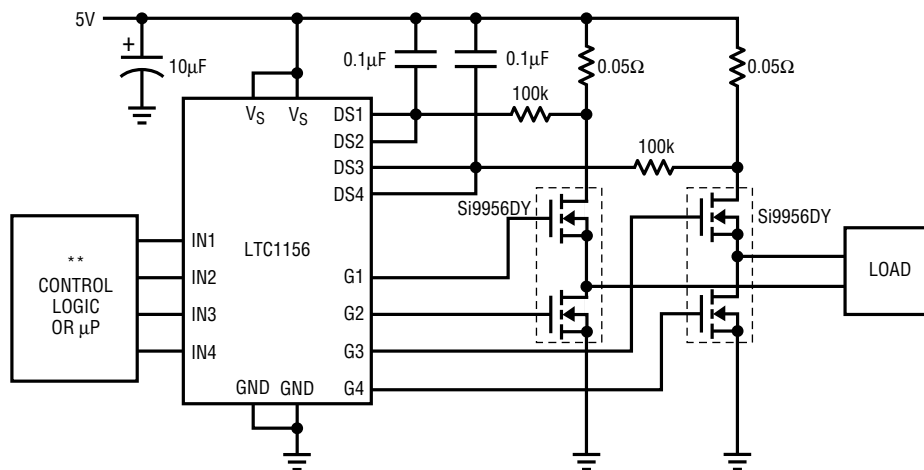

For more Typical Applications, see LTC1155 data sheet.

PACKAGE DESCRIPTION Dimensions in inches (millimeters) unless otherwise noted.

**N Package
16-Lead Plastic DIP**

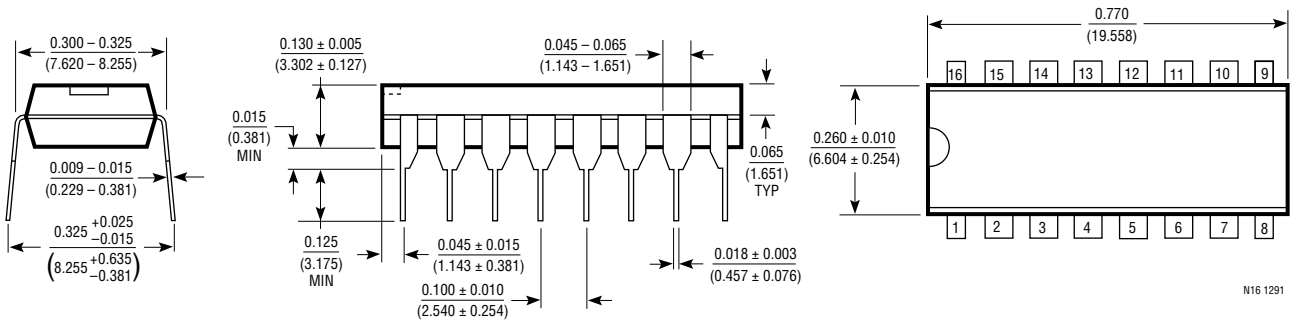

**S Package
16-Lead Plastic SOL**

